



TECHNISCHE FICHE

Bsoul WATEROPSLAGTANK VOOR VERWARMING EN KOELING



Technische gegevens

| Spec | | Bsoul-50L | Bsoul-100L | Bsoul-200L | Bsoul-300L | Bsoul-400L | Bsoul-500L |
|----------------------------------|------|------------------------|------------|------------|------------|------------|------------|
| Opslagvolume | L | 50 | 100 | 200 | 300 | 400 | 500 |
| Tank materiaal | | Duplex Roestvast Staal | | | | | |
| Max. werkdruk | MPa | 0.6 | 0.6 | 0.6 | 0.6 | 0.6 | 0.6 |
| Max. testdruk | MPa | 1.0 | 1.0 | 1.0 | 1.0 | 1.0 | 1.0 |
| Max. watertemperatuur | °C | 90 | 90 | 90 | 90 | 90 | 90 |
| Hydraulische aansluiting | " | 1-1/2 | 1-1/2 | 1-1/2 | 1-1/2 | 1-1/2 | 1-1/2 |
| Verschuiving hydr. aansluitingen | ° | 180 | 180 | 180 | 180 | 180 | 180 |
| Elek. hulpverwarmer aansluiting | " | - | 1-1/2 | 1-1/2 | 1-1/2 | 1-1/2 | 1-1/2 |
| Ontluchter aansluiting | " | 1-1/4 | 1-1/4 | 1-1/4 | 1-1/4 | 1-1/4 | 1-1/4 |
| Afvoer aansluiting | " | 3/4 | 3/4 | 3/4 | 3/4 | 3/4 | 3/4 |
| Temperatuursensor aansluiting | " | 1/2 | 1/2 | 1/2 | 1/2 | 1/2 | 1/2 |
| Netto gewicht | kg | 15 | 23 | 36 | 56 | 68 | 85 |
| Isolatie type | | PU | PU | PU | PU | PU | PU |
| Thermische geleidbaarheid | W/mK | ≤0.021 | ≤0.021 | ≤0.021 | ≤0.021 | ≤0.021 | ≤0.021 |
| Isolatie dikte | mm | 50 | 50 | 45 | 50 | 50 | 50 |

Opmerking: Bsoul-50L en Bsoul-100L worden geleverd met een muurbeugel.

| Spec | | Bsoul-600L** | Bsoul-800L** | Bsoul-1000L** | Bsoul-2000L** |
|----------------------------------|------|------------------------|--------------|---------------|---------------|
| Opslagvolume | L | 600 | 800 | 1000 | 2000 |
| Tank materiaal | | Duplex Roestvast Staal | | | |
| Max. werkdruk | MPa | 0.6 | 0.6 | 0.6 | 0.6 |
| Max. testdruk | MPa | 1.0 | 1.0 | 1.0 | 1.0 |
| Max. watertemperatuur | °C | 90 | 90 | 90 | 90 |
| Hydraulische aansluiting | " | 1-1/2 | 1-1/2 | 1-1/2 | 1-1/2 |
| Verschuiving hydr. aansluitingen | ° | 180 | 180 | 180 | 180 |
| Elek. hulpverwarmer aansluiting | " | 1-1/2 | 1-1/2 | 1-1/2 | 1-1/2 |
| Ontluchter aansluiting | " | 1-1/4 | 1-1/4 | 1-1/4 | 1-1/4 |
| Afvoer aansluiting | " | 1 | 1 | 1 | 1 |
| Temperatuursensor aansluiting | " | 1/2 | 1/2 | 1/2 | 1/2 |
| Netto gewicht | kg | 102 | 108 | 140 | 240 |
| Isolatie type | | PU | PU | PU | PU |
| Thermische geleidbaarheid | W/mK | ≤0.021 | ≤0.021 | ≤0.021 | ≤0.021 |
| Isolatie dikte | mm | 50 | 50 | 50 | 75 |

**Alleen beschikbaar op aanvraag.

Opmerking: Bsoul-2000L wordt geleverd met 2 hijsogen aan de bovenkant.

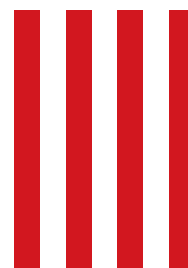

AFMETINGEN (in mm)

Bsoul-50L

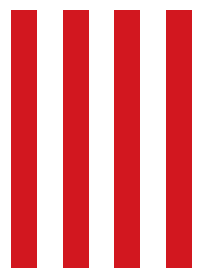
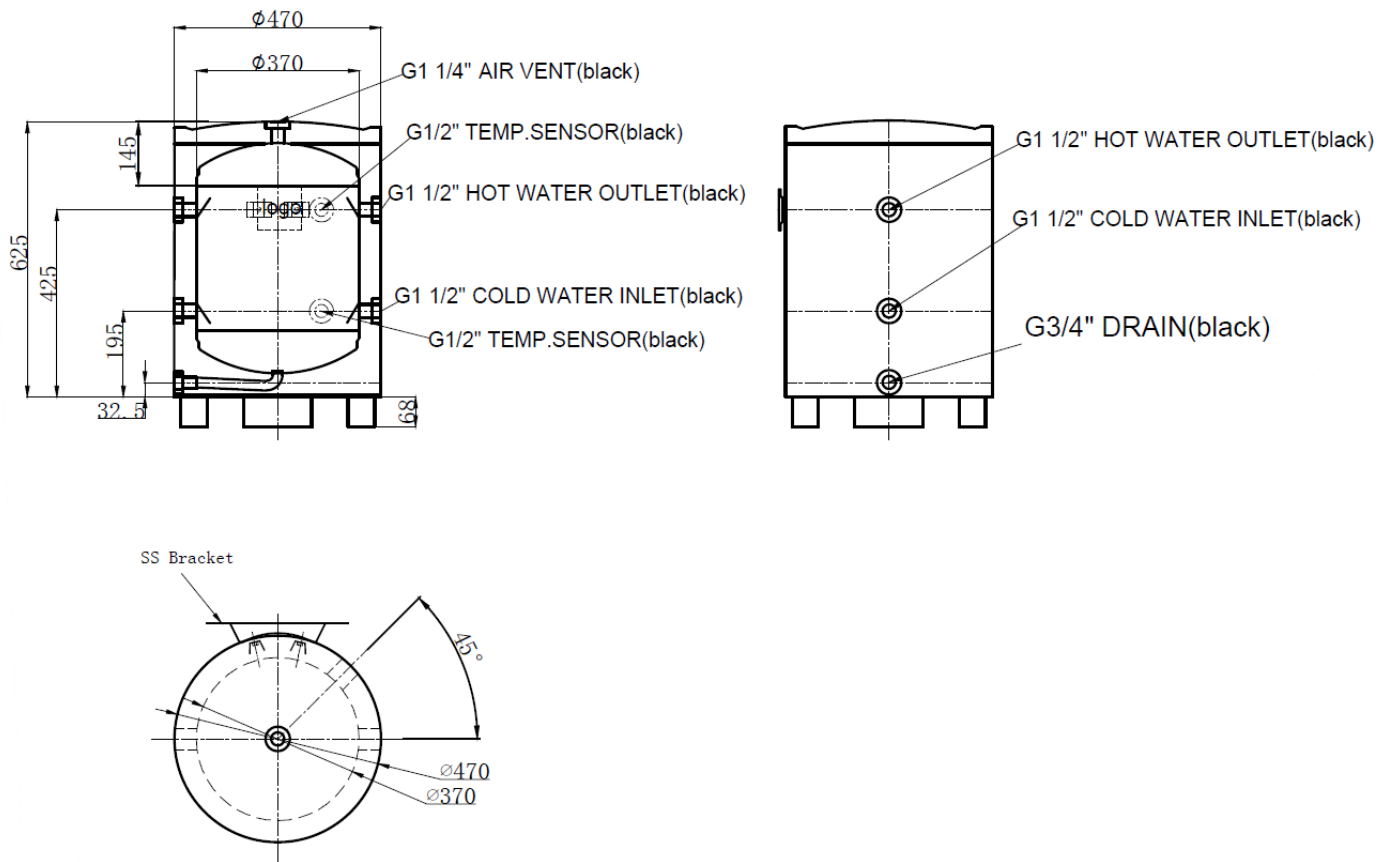

Bsoul-100L

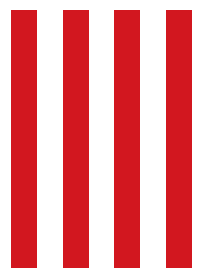
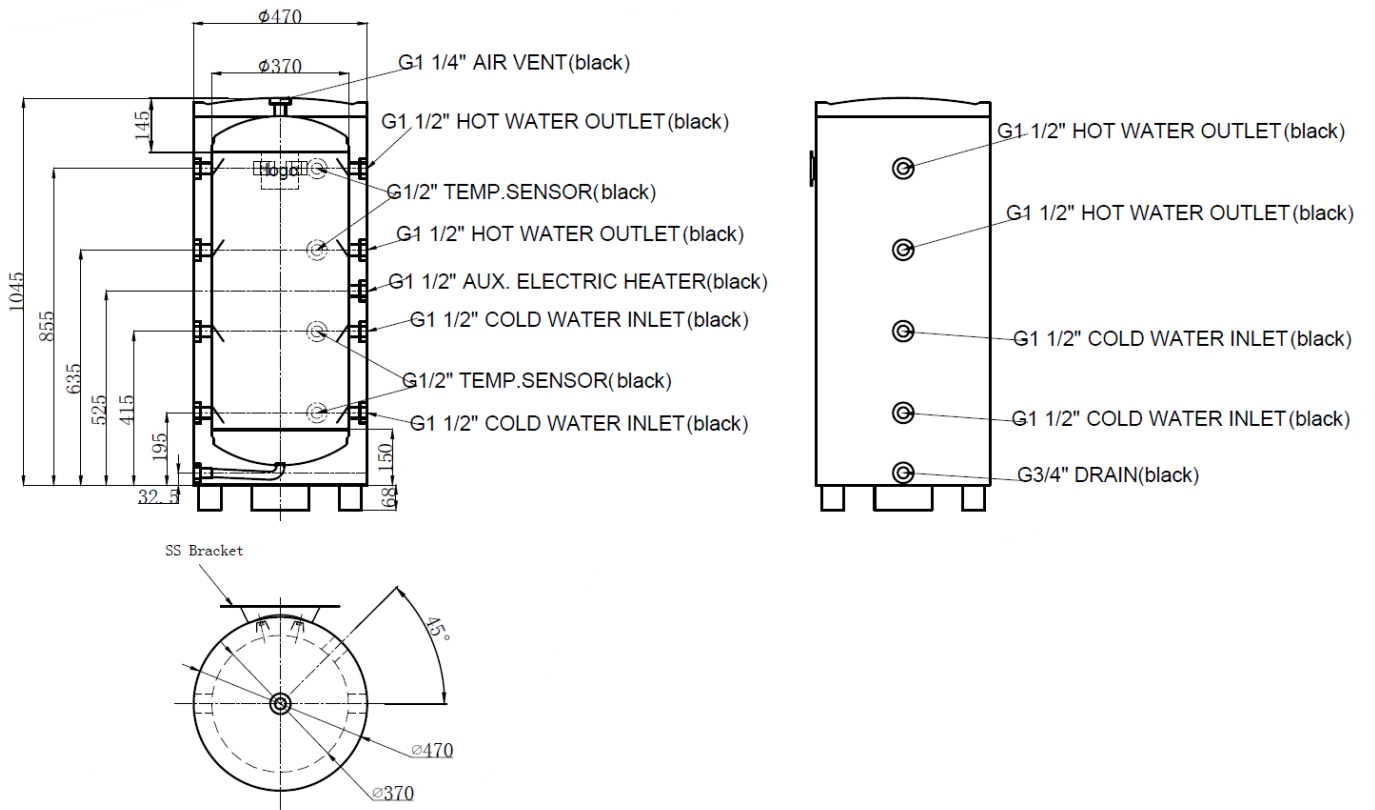

Bsoul-200L

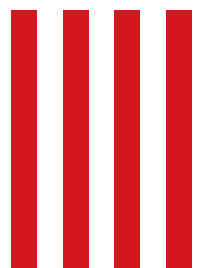
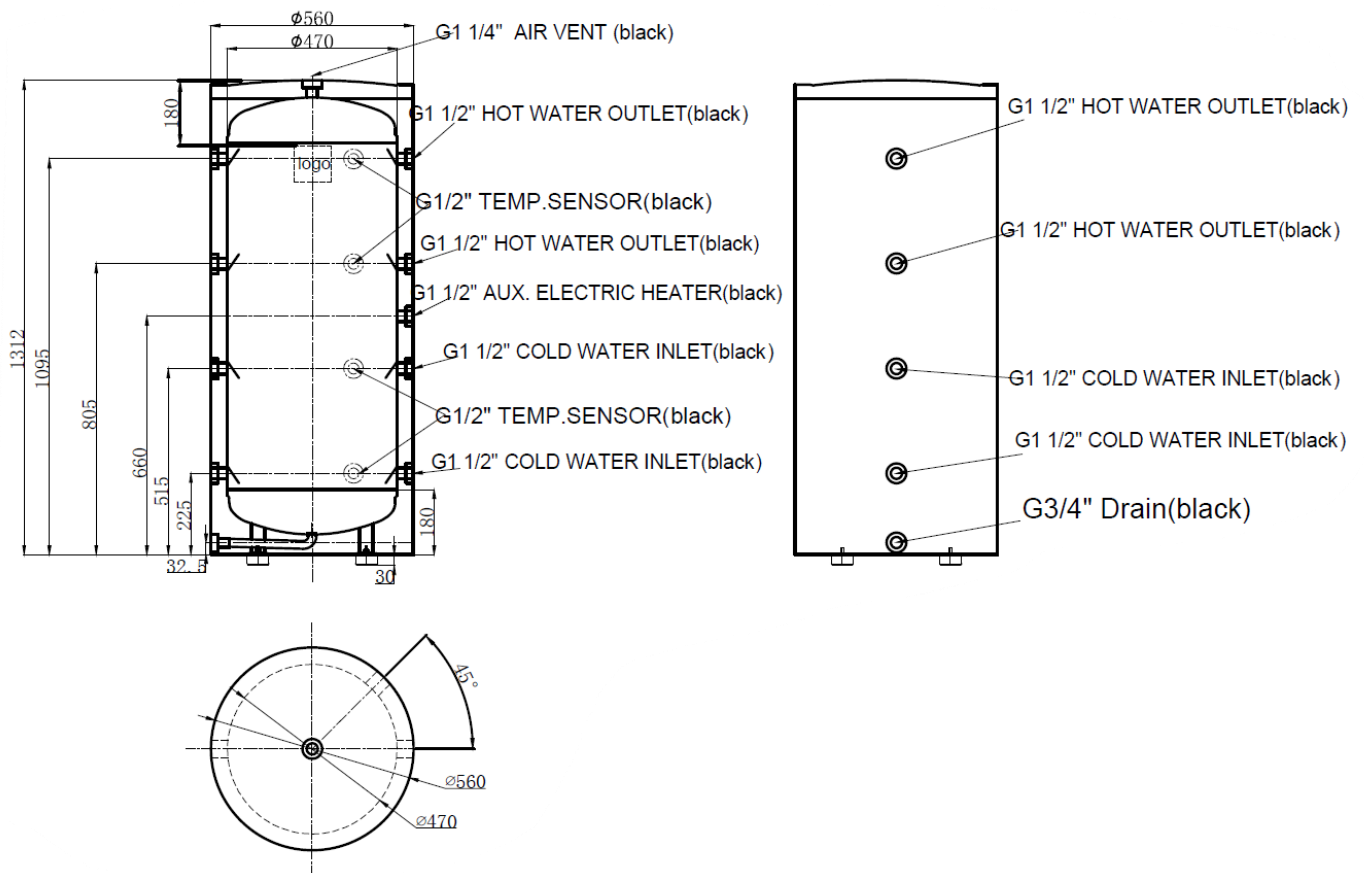

Bsoul-300L

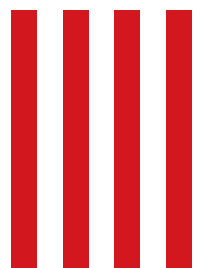
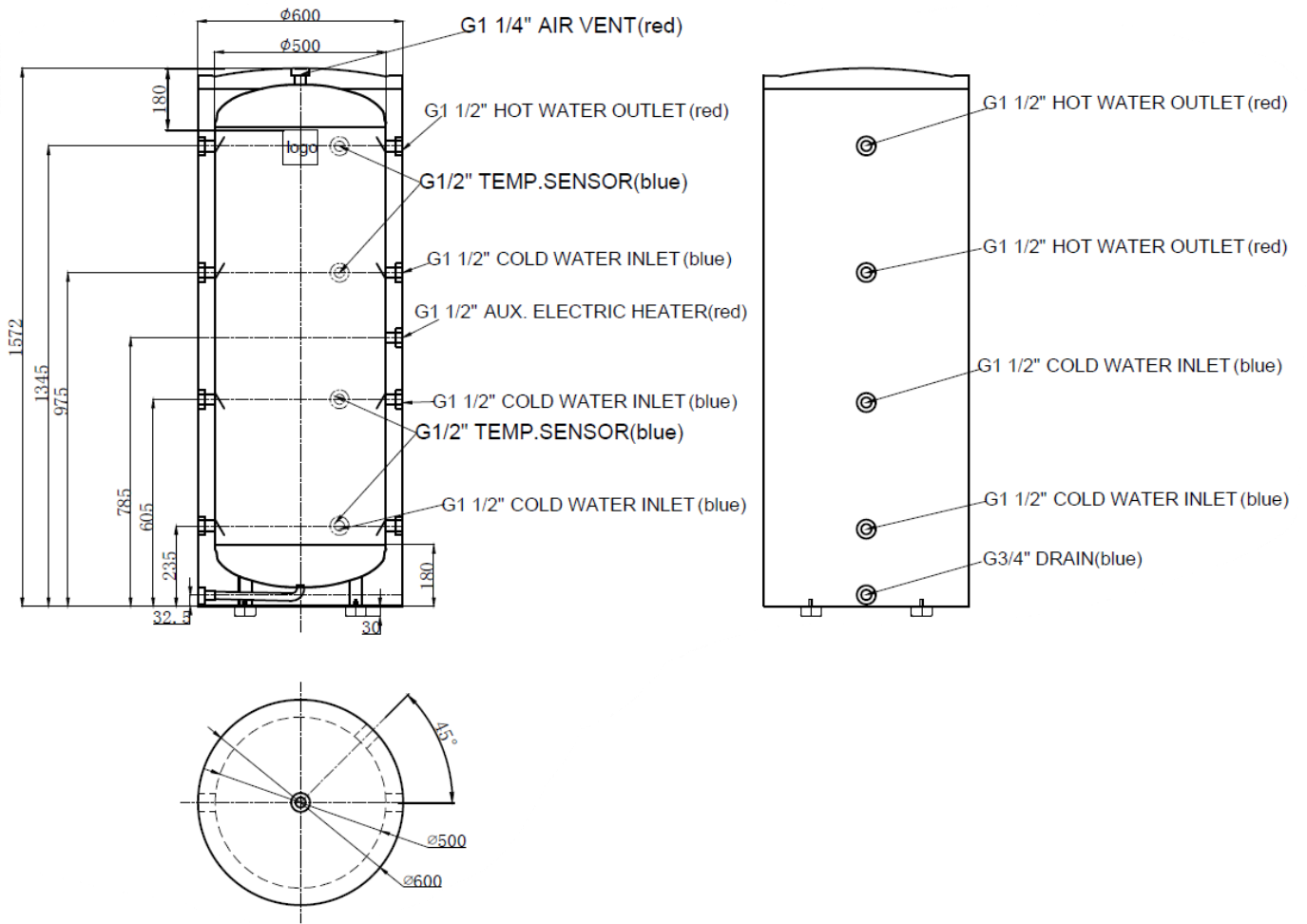

Bsoul-400L

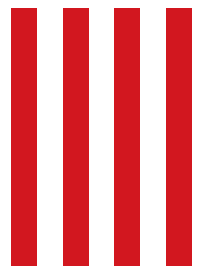
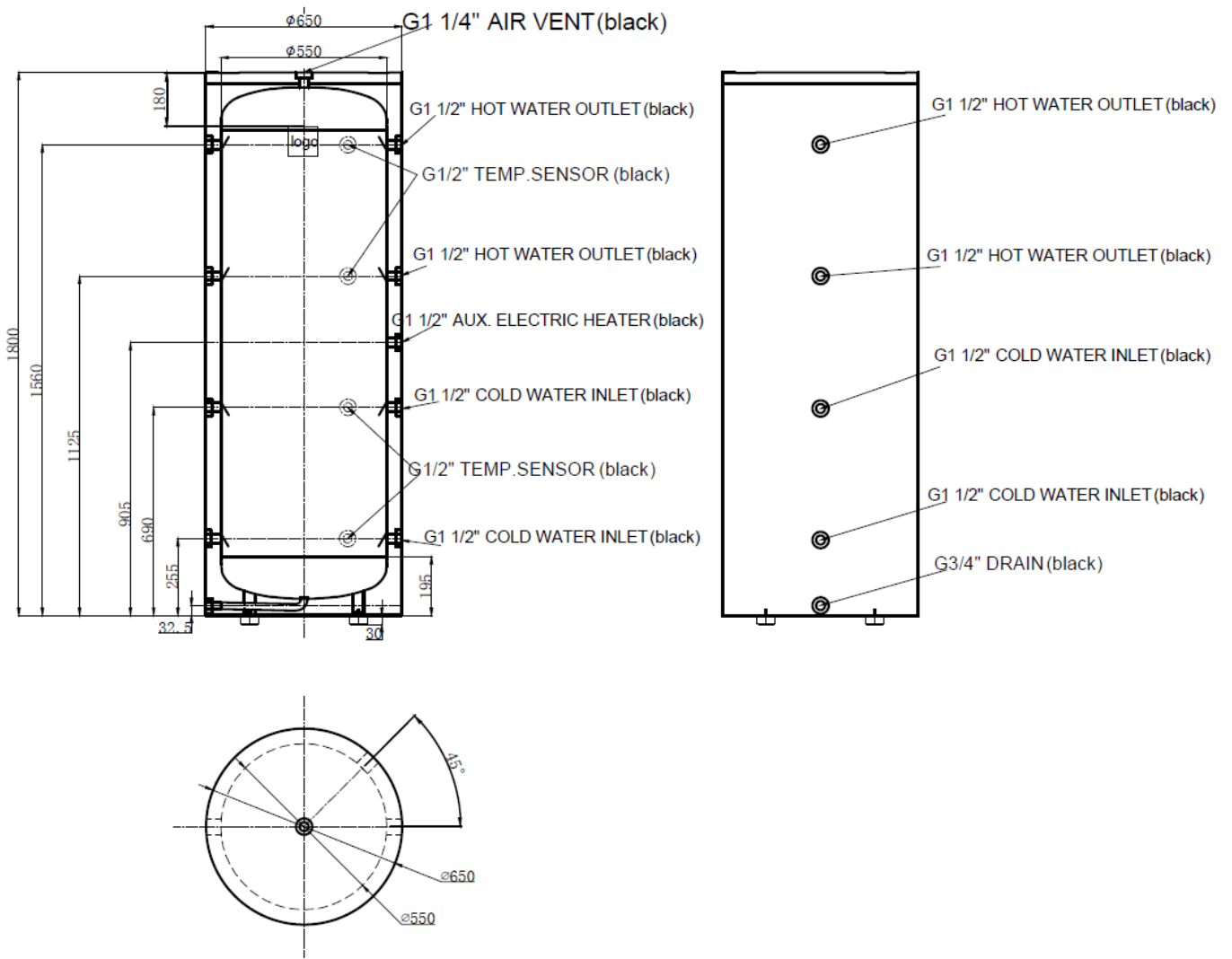

Bsoul-500L

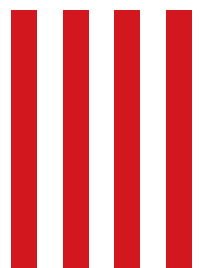
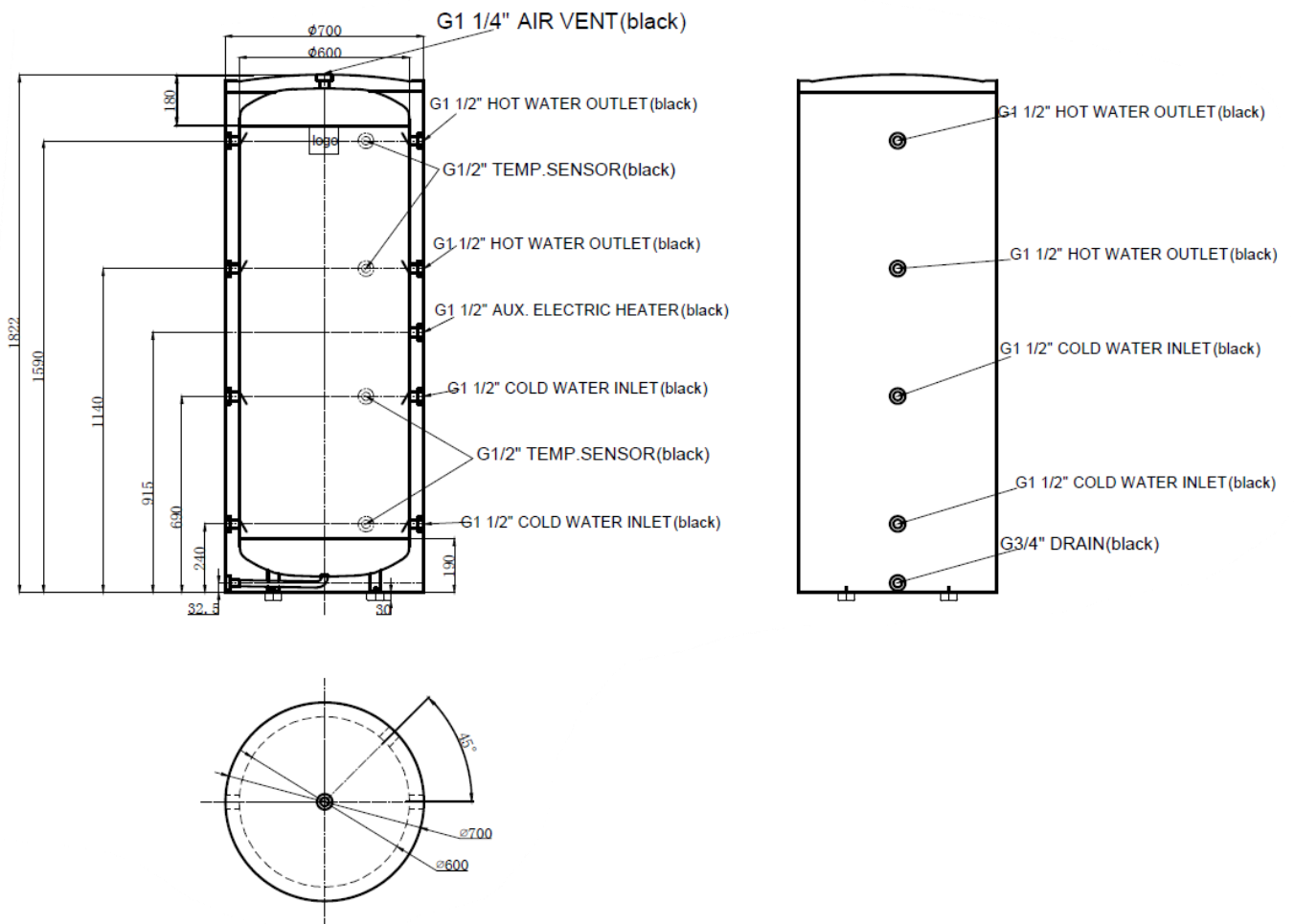

Bsoul-600L

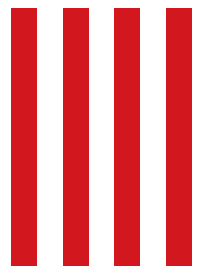
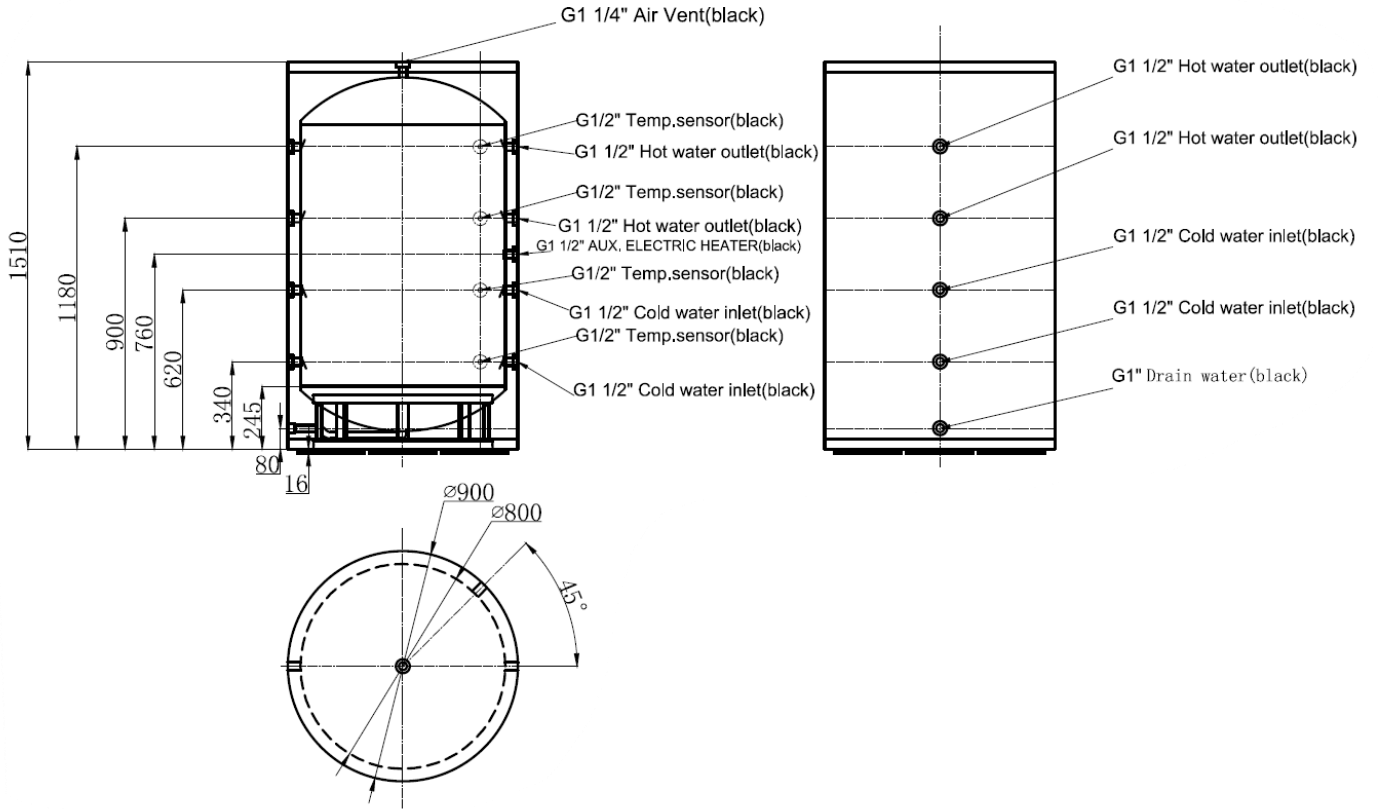

Bsoul-800L

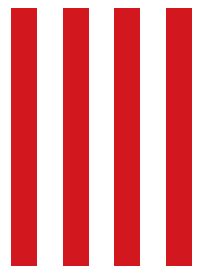
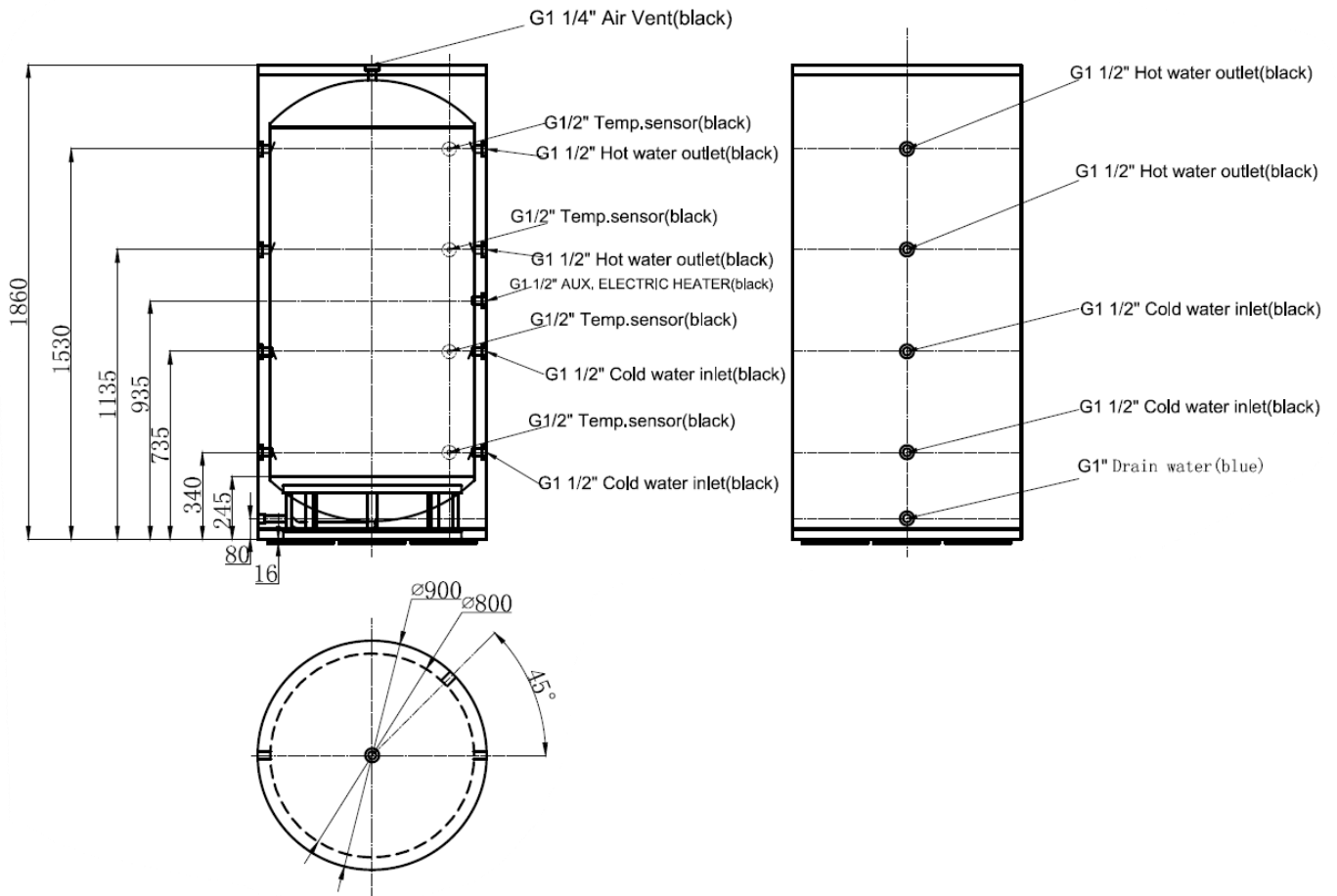

Bsoul-1000L

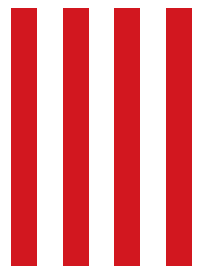
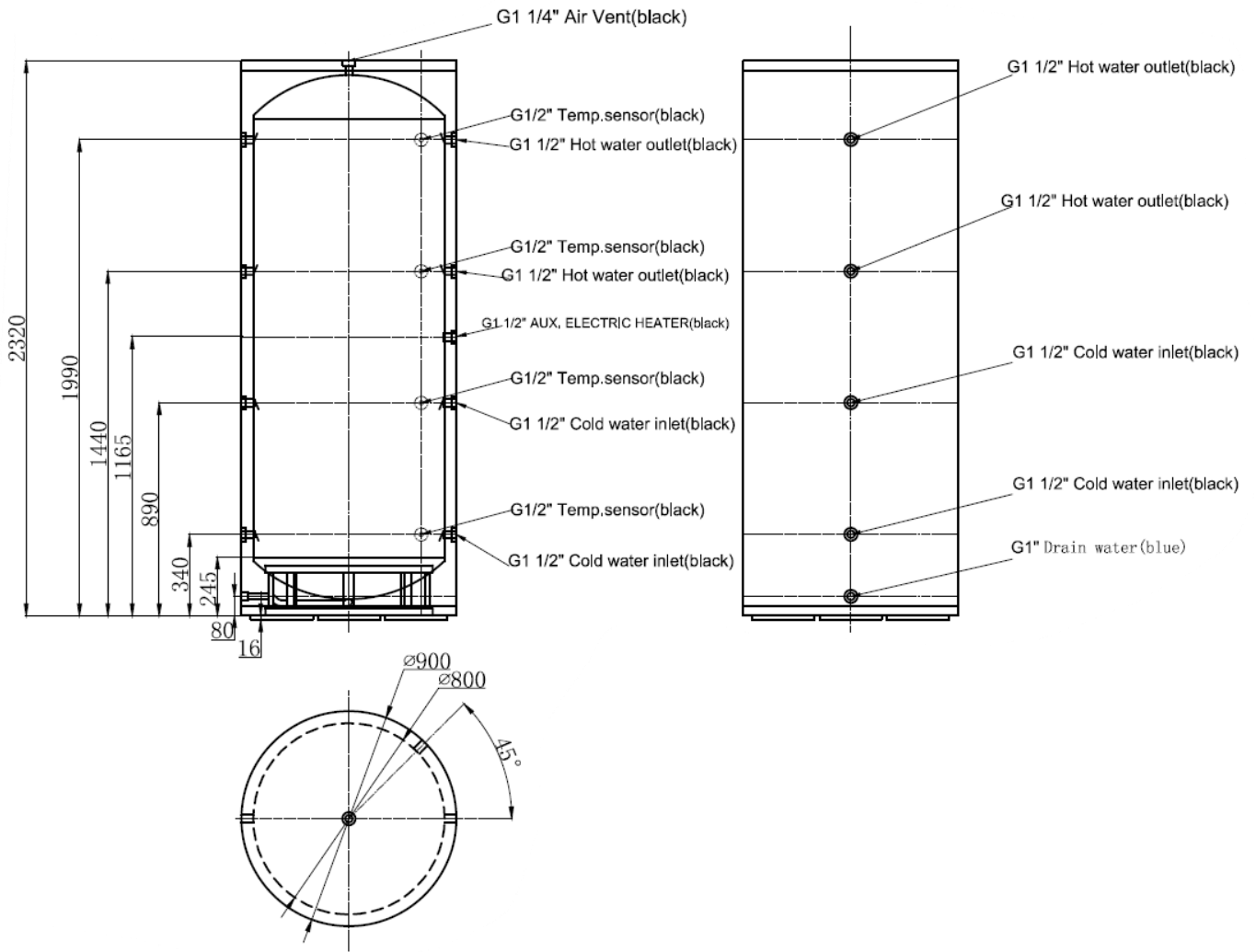

Bsoul-2000L

